

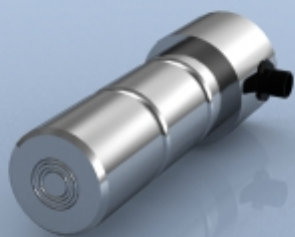

## TYPE: CWM-LP



# CWM-LP Stainless Steel Container Weighing Load Measuring Pin

## Description

The LCM container weighing load pin offers precision force measurement by replacing existing pins in the spreader or headerblock of straddle carriers, container cranes and reach stackers. Each CWM-LP load pin is custom designed to the exact measurements of the load bearing pin it is replacing. They offer a non intrusive method of load measurement, as no modifications are required to existing equipment.

The CWM-LP load pin range is available in ratings from 1te to 50te and are built to exacting standards. They are proof loaded to 150% of normal rated load and are temperature compensated. The load pins employ a full strain gauge bridge as its measurement technology. They are also extremely durable under even the harshest working conditions and have a long operational life.

The load pins have a radial mounted connector so the pins can easily be installed without cables getting in the way, and are supplied with pre-wired cable assemblies for simple and fast connection to the CWM-1 interface module. This also allows untrained personnel to install the load pins, as no system wiring during the installation process is required. Wiring errors are also eliminated.

## Specification

Rated load (tonne)	1 tonne to 50 tonnes (higher available on request)
Proof load	150% of rated load
Ultimate breaking load	>300% of rated load
Output	1.5mV/V at rated load (nominal)
Non-linearity	<±0.2 to ±1.5% of rated load typically, depending on pin geometry
Non-repeatability	<±0.04% of rated load
Excitation voltage	10vdc recommended, 15vdc maximum
Bridge resistance	1000Ω
Insulation resistance	>500MΩ @ 500vdc
Operating temperature range	-20 to +70°C
Compensated temperature range	-10 to +70°C
Zero temperature coefficient	<±0.01% of rated load/°C
Span temperature coefficient	<±0.01% of rated load/°C
Environmental protection level	As required (standard IP67)
Connection type	10 metre 4-core screened cable assembly
Wiring connections	+ve supply: Red    -ve supply: Blue +ve signal: Green    -ve signal: Yellow

## Available Options

- Integral signal conditioning
- Special electrical connectors

## Features

- Ranges from 1te to 50te
- Stainless steel construction
- Environmentally sealed to IP67
- Supplied with integral connector
- Supplied with pre-wired cable assemblies

## Typical Applications

- Container weighing
- Eccentrically loaded container identification
- Twistlock damage identification
- Container overload prevention

# CWM-LP Stainless Steel Container Weighing Load Measuring Pin

## Dimensions

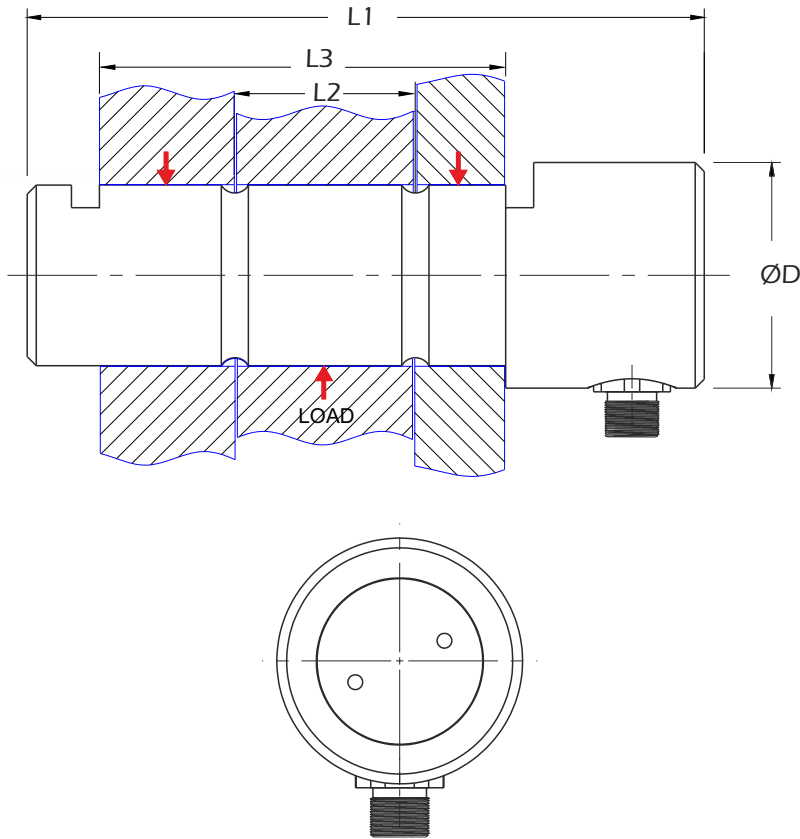

All dimensions are in mm

Rating (tonne)	Part No.	ØD	L1	L2	L3
ALL	LCMXXXX	As required	As required	As required	As required

If you would like to receive a quotation for a container weighing load pin, please visit our website at [www.lcmsystems.com/lpq](http://www.lcmsystems.com/lpq) and fill in our Load Pin Questionnaire

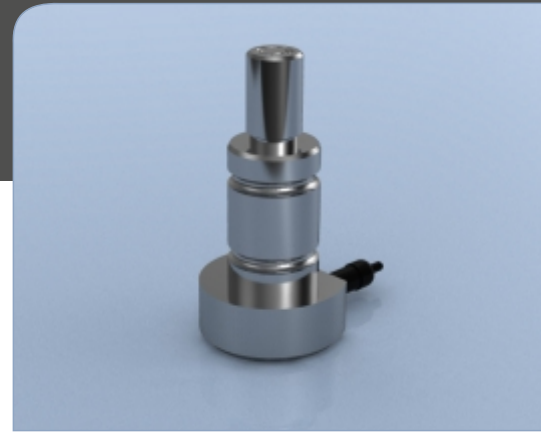

www.lcmsystems.com

**LCM Systems Ltd**  
 Unit 15, Newport Business Park, Barry Way  
 Newport, Isle of Wight PO30 5GY UK  
 Tel: +44 (0)1983 249264  
[sales@lcmsystems.com](mailto:sales@lcmsystems.com)  
[www.lcmsystems.com](http://www.lcmsystems.com)

Due to continual product development, LCM Systems Ltd reserves the right to alter product specifications without prior notice.

**Issue No. 1**  
 Issue date: 23/02/2016  
 APPROVED  
 (unapproved if printed)



# CWM-IF Diecast Aluminium Interface Module (CWM-1)

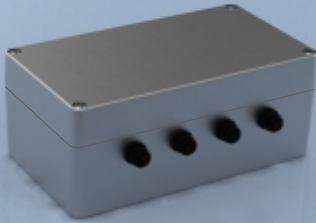

## Description

The LCM container weighing interface module consists of a diecast aluminium converter/junction box with DSC digital load cell conditioning units (one per load pin). The DSC is a high performance digital signal conditioner that takes the mV/V output of the load pin and converts it into an RS485 signal. These DSC cards enable the building of a highly accurate measurement system through the use of the built in linearisation and temperature compensation facilities, which allows calibration to be carried out once the system has been installed.

The interface module itself enables the connection of the load pins and DSC cards to a multi-dropped digital communications bus to offer a convenient and practical solution to the integration of load cells with weighing systems where connection to a tablet, PC, PLC or TOS is required.

Connection of the interface module to the load pins and tablet is easily achieved via the connection pack, which contains all connector and cable assemblies required to connect together all the individual system components. This ensures installation is simple and fast, which reduces costs by eliminating the need for skilled personnel to carry out the commissioning and by reducing equipment downtime.

At LCM Systems we offer a flexible solution to most load monitoring solutions and have many standard interface options available. Please discuss your requirements with our technical or sales team and they will be able to advise and assist you, to offer you the most cost effective and technically compatible system available.

## Specification

Bridge excitation (V)	4.25 to 5.25 (5 typical)
Bridge impedance (Ohms)	320 to 5000 (350 typical)
Sensor impedance: 18V supply (Ohms) *	320 to 5000 (350 typical)
Sensor impedance: 12V supply (Ohms) *	320 to 5000 (350 typical)
Bridge sensitivity (mV/V)	-3 to +3
Offset temperature stability (ppm/°C)	5 (10 max)
Gain temperature stability (ppm/°C)	30 (50 max)
Offset stability with time (%FR)	0.0035 (0.016 max)
Gain stability with time (ppmFR/1st year)	300
Non linearity (%FR)	0.0005 (0.0025 max)
Internal Resolution (counts/divisions)	16 million
Resolution @ 1Hz (noise stable)	66,000
Power supply voltage (Vdc)	12/24VDC (9-36VDC)
Power supply noise/ripple (mVac pk-pk)	100
Excitation system	4 wire
Connections	1 x 10m cable assembly <b>per load pin</b> for load cell connection 1 x 25m cable assembly for connection to tablet/PC/PLC
Environmental sealing	Sealed to IP67
Operating temperature range	-40 to +85°C
Storage temperature range	-40 to +85°C
Relative humidity	95% maximum non condensing

\* Subject to supply voltage

## Available Options

- Various outputs available for integration with terminal operating systems (TOS)
- Special electrical connectors

## Features

- Noise immunity 5x heavy industrial level
- Real mV/V calibration
- Very high stability
- Rated to IP67
- Diecast aluminium construction
- No installation wiring required

## Typical Applications

- Container weighing
- Eccentrically loaded container identification
- Twistlock damage identification
- Container overload prevention

### LCM Systems Ltd

Unit 15, Newport Business Park  
Barry Way, Newport  
Isle of Wight PO30 5GY UK  
Tel: +44 (0)1983 249264  
Fax: +44 (0)1983 249266  
sales@lcmsystems.com  
www.lcmsystems.com

# CWM-IF Diecast Aluminium Interface Module (CWM-1)

## CWM-1 Module Use

When used in the CWM-1 system (which includes the supply by LCM Systems of the in-cab mounted tablet PC used to display the container weight to the operator), the CWM-IF interface module provides a proprietary RS485 signal back to the cab. The software used to display the weight takes care of all communications as part of the software package.

## Dimensions

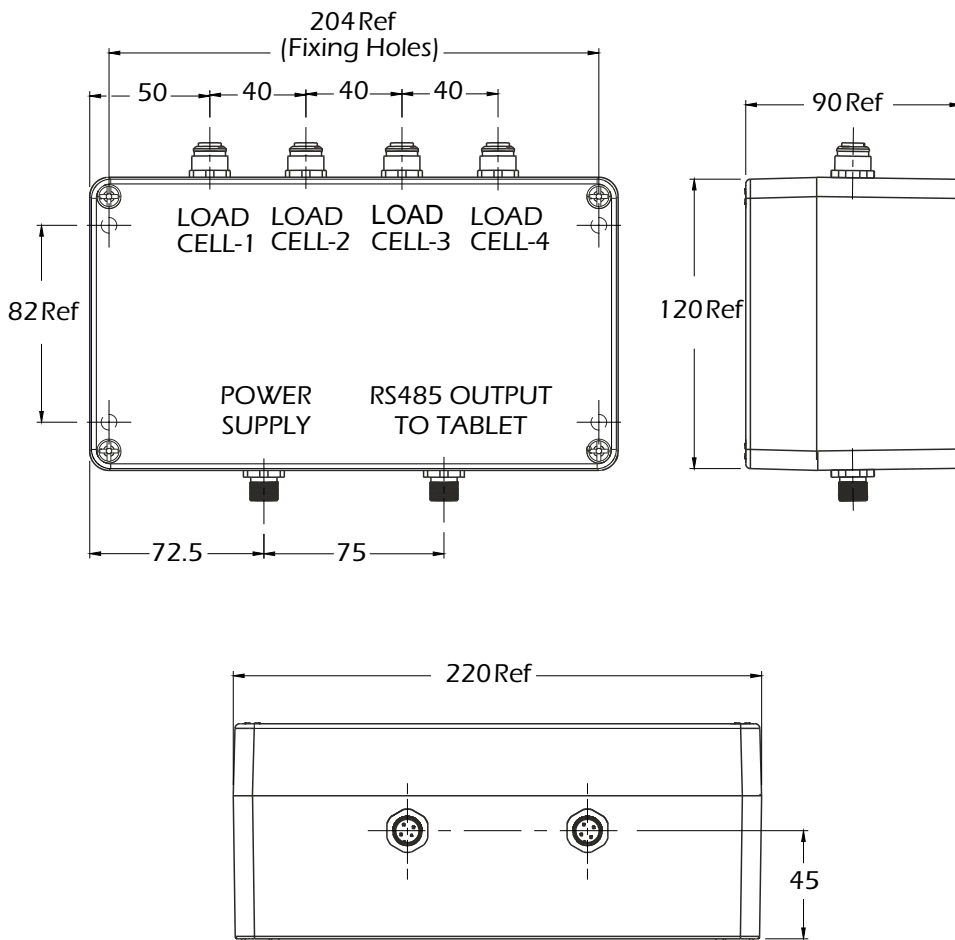

All dimensions are in mm

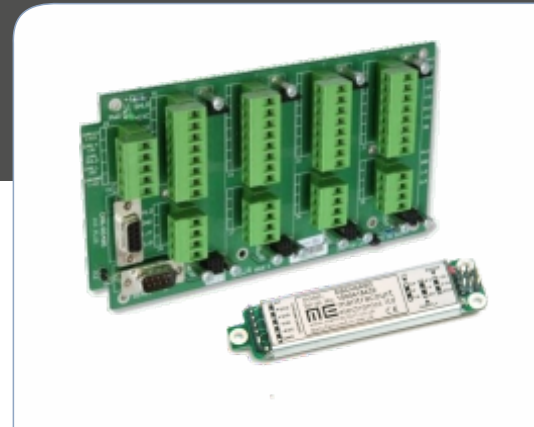

www.lcmsystems.com

### LCM Systems Ltd

Unit 15, Newport Business Park, Barry Way  
Newport, Isle of Wight PO30 5GY UK

Tel: +44 (0)1983 249264

sales@lcmsystems.com

www.lcmsystems.com

Due to continual product development, LCM Systems Ltd reserves the right to alter product specifications without prior notice.

### Issue No. 1

Issue date: 23/02/2016

APPROVED

(unapproved if printed)



# CWM-TB Rugged 8" Tablet

## Description

The CWM-TB is a rugged tablet PC with an 8" toughened glass display that is only 16mm thick and weighs just 630g. Although sleek and lightweight it is also incredibly tough, drop tested to 1.2m, and certified to IP67, making it ideal for harsh dockside environments.

The tablet displays data from the CMW-1 container weighing system, giving the load on each twistlock and the percentage of the overall weight it is carrying. This enables the detection of possible damage to twistlocks due to overloading or unequal weight distribution during container engagement and lifting. Also displayed is the combined weight on all four of the twistlocks. There is a tare function and the facility to enter container numbers and generate reports. A calibration button on the main screen takes you to a new display screen, where you can calibrate the system on-site for optimal accuracy.

Data is stored in the tablets 32GB storage, and can be downloaded to a USB or direct to a PC for printing or for future analysis. A cab mount is also supplied for fixing to the cabin, and the super-bright and anti-reflective touch screen ensures it is suitable for use in all lighting conditions.

Connection to the interface module is via a pre-wired cable assembly for simple and fast set-up.

## Specification

OS	Windows 10 Industry Pro
Display	8 inch IPS display, 1280 x 800 resolution
Touch	5-point capacitive multi-touch screen. 7H hardness
CUP	Intel Baytrail Quad-Core Z3735F 1.33-1.83GHz
Memory	2GB RAM DDR3
Storage	Solid State Drive 32GB mSATA
Interfaces	2 x USB 2.0 (1 x Micro OTG with adaptor, supports charging), micro SDXC card (max 64GB), DC-in, 3.5mm audio-out, SIM slot (micro), HDMI-out 1.4a Type C (mini), 12 pin Pogo docking connector
WLAN	WiFi 802.11 a/b/g/n dual-band
Bluetooth	Bluetooth 4.0 LE
Sensors	Accelerometer, gyroscope, compass, ambient light
Power	DC 5V/3A via DC-in. DC 5V/1-2A via micro USB
Battery	8,300mAh / 3.7V
Weight	630g
Dimensions	228 x 147 x 16.5mm
IP Rating	IP67
Operating temperature	-10° to +60°C
Drop test	1.2m
Accessories	Hand strap, DC charger, micro USB adaptor, USB cable, cab mount

## Available Options

- Docking station (3 x USB, 1 x RJ45, 1 x DC-in)
- Different mounting options
- 2 or 4 load pin/load cell system

## Features

- Anti-scratch, toughened glass touch screen
- Environmentally sealed to IP67
- 1280 x 800 resolution
- 2 USB ports
- 32GB storage (solid state drive)
- Supplied with cab mount
- Windows 10 OS
- Bright, anti-reflective screen
- Tonne, kg, lb weighing units

## Typical Applications

- Container weighing
- Eccentrically loaded container identification
- Twistlock damage identification
- Container overload prevention

### LCM Systems Ltd

Unit 15, Newport Business Park  
 Barry Way, Newport  
 Isle of Wight PO30 5GY UK  
 Tel: +44 (0)1983 249264  
 Fax: +44 (0)1983 249266  
 sales@lcm systems.com  
 www.lcm systems.com



# CWM-LP Rugged 8" Tablet

## Dimensions



Calibration screen



www.lcmsystems.com

LCM Systems Ltd  
 Unit 15, Newport Business Park, Barry Way  
 Newport, Isle of Wight PO30 5GY UK  
 Tel: +44 (0)1983 249264  
 sales@lcm systems.com  
 www.lcm systems.com

Due to continual product development, LCM Systems Ltd reserves the right to alter product specifications without prior notice.

Issue No. 1

Issue date: 23/02/2016

APPROVED

(unapproved if printed)