



Operator Instructions for Load Measuring Links

Types: TLL, TOG & WLL



CONTENTS

1. OPERATING INSTRUCTIONS	
1.1 Introduction	1
1.2 Markings CE	1
1.3 Electromagnetic Compatibility (EMC)	1
1.4 Load Link Type/Model Number	1
1.5 Installation and Operation	2
1.6 Calibration	4
1.7 Warnings / Hazards	5
1.8 Inspection and Repair	5
2. DRAWINGS AND SPECIFICATIONS	
2.1 Load Link Specifications	6
2.2 Cable Gland and Connector Configurations	6
2.3 Load Link Output Options	8
3. DECLARATION OF CONFORMITY	9
4. NOTICE	
4.1 Copyright	10
4.2 About	10

OPERATING INSTRUCTIONS

1.1 Introduction

This instruction manual refers to the LCM Systems range of load links and includes instructions for both cabled and telemetry options. Before installing or operating any LCM Systems load link, this and any reference documents should be read and understood.

In compliance with the Machinery Directive, LCM Systems load links will be supplied with the following documents: Instruction Manual, Calibration Certificate and a Declaration of Conformity.

These load measuring devices were designed and manufactured to be installed as partly completed machinery into a machine or partly completed machine.

These instructions must be retained and incorporated in the technical documentation for the machine or partly completed machinery into which the load link is installed.

All LCM Systems load links are designed and manufactured to LCM Systems Quality Management System which is written in accordance with ISO 9001:2008

LCM Systems load links affixed with the **CE** mark, are manufactured in compliance with the Machinery Directive 2006/42/EC and the following harmonised standards:

- BS EN ISO 13849-1:2015 Safety of machinery - Safety-related parts of control systems
Part 1: General principles for design
- BS EN ISO 13849-2:2015 Safety of machinery - Safety-related parts of control systems
Part 2: Validation

1.2 Markings CE

Each load link will be marked with an individual serial number, CE label and the SWL (safe working load) of the load link.

1.3 Electromagnetic Compatibility (EMC)

The electromagnetic compatibility of the load cell device can only be assessed in conjunction with the entire installation, including its control systems. The machine builder who installs this partly completed machinery into a machine is responsible for compliance with the EMC directive.

1.4 Load Link Type/Model Number

Load Link: TLL, TOG, WLL and LCMXXXX (custom design)

All LCM Systems load link designs are allocated a unique LCM number/model number. i.e. LCM Number = LCMXXXX (where X= 0-9 i.e. LCM4203) or a model number (i.e. TLL-10). LCM Systems send a drawing to the customer for approval prior to the manufacture of any custom designed load link.

Supplier:

LCM Systems Ltd
Unit 15, Newport Business Park,
Barry Way, Newport
Isle of Wight PO30 5GY
United Kingdom

Tel: +44(0)1983 249264
Fax: +44(0)1983 249266
e-mail: sales@lcmsystems.com

Service: (REPAIR, SUPPORT)

LCM Systems Ltd (address as above)

1.5 Installation and Operation

To ensure safe and trouble free installation of the load link measuring device, the load link must be properly transported and stored, professionally installed and placed in operation.

Unpacking

Before removing the load link, inspect the packaging for signs of damage and immediately inform the supplier if any damage is found. Unpack the load link carefully, taking special care with cables and be aware to the possibility of damaging low range devices by mishandling. Ensure that calibration and instruction information is not inadvertently discarded.

Checks Prior to Installation

- ⦿ If the load link is fitted with a cable and gland, check that the cable is held securely by the gland.
- ⦿ If the load link is fitted with a connector, check the connector is secure to the pin, check the plug and socket for any damage and check that the connector mates correctly.
- ⦿ Check the cable for damage, such as cuts or abrasions, especially where the cable enters the gland or connector assembly.
- ⦿ Check that the load link has been suitably selected for the environment it is being placed into. Any adverse temperature, corrosive or potentially explosive environments may affect the operational life and the safety of the product.
- ⦿ If the load link is fitted with a telemetry module, check that the 2 off AAA batteries are correctly installed, that the two RED clips on the telemetry housing are closed and that the battery cover is secure. See figure 1 for details.

Figure 1

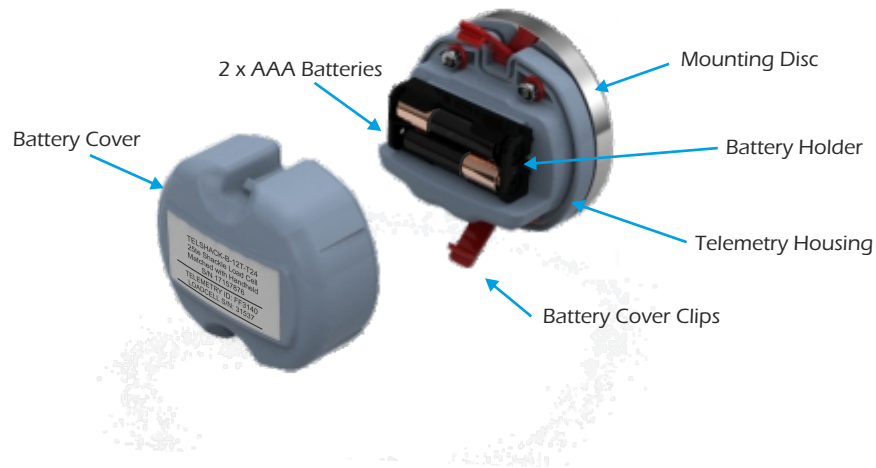

Installation

Load links are normally classified as portable devices, and so the correct installation is critical to ensuring product life cycle. To avoid damage or loss of accuracy during installation, the following points should be followed.

- ⦿ The direction of the load applied to a link should be linear as shown in figures 2 & 3.
- ⦿ Ensure the load link does not experience torque or bending forces during operation.
- ⦿ The load link should only be loaded in tension using the \varnothing C holes as shown see figure 2 & 3. See figure 4 for two common examples of installations.

- For optimal performance a tight tolerance with the $\varnothing C$ loading holes is recommended.
- If the load link is fitted with a telemetry unit then ensure that a clear line-of-sight between the transmitter and receiver is maintained and that objects or structures are kept at least one metre away from antennae wherever possible. The installer should also first read the T24 Telemetry User Manual which can be found at the following web address: <http://www.lcmsystems.com/T24>.

Figure 2

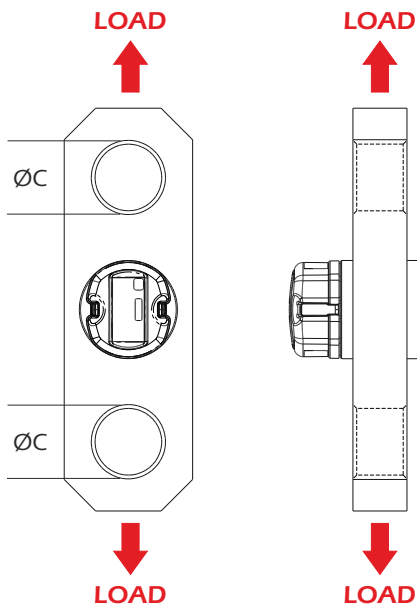

Figure 3

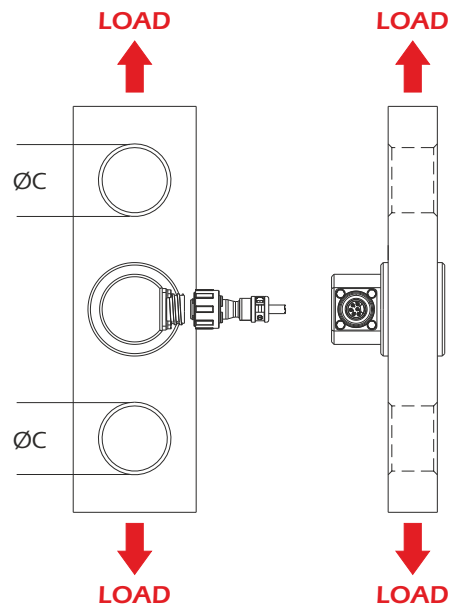
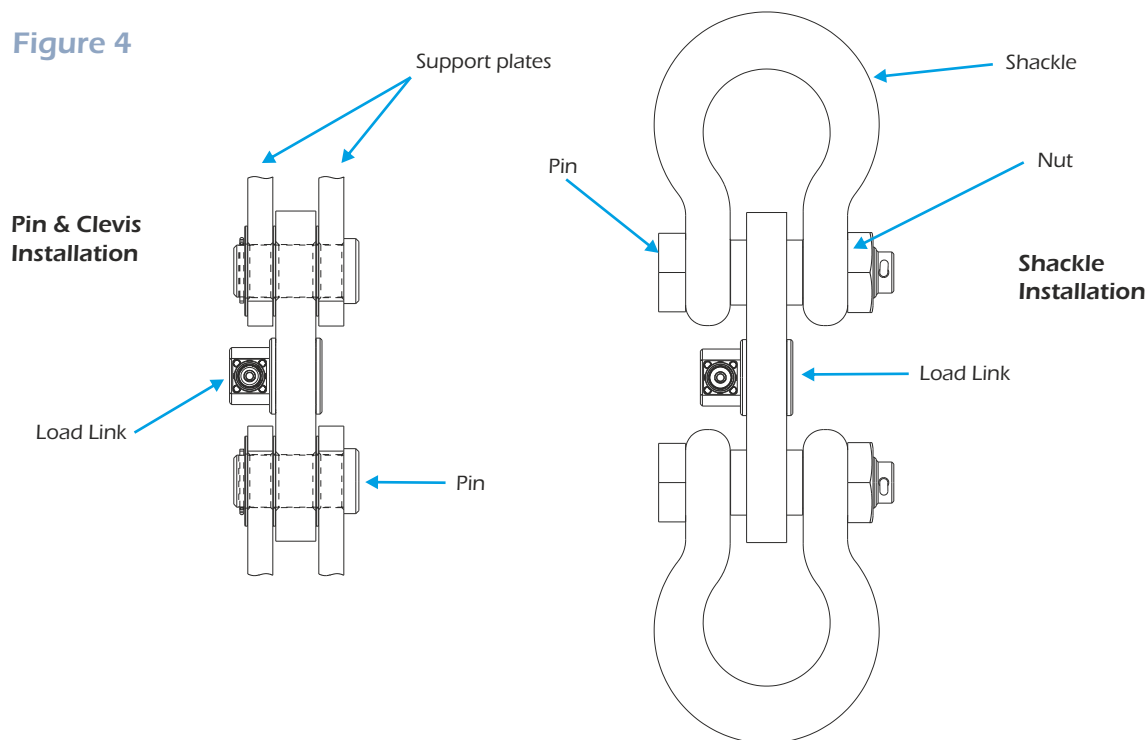

Figure 4



Wiring and Electrical Checks

The correct connection of a load link to an instrument is critical to achieving and maintaining the performance and reliability of the load cell.

- ⦿ Wiring connections are given on the calibration certificate supplied with each load link.
- ⦿ Where a screened cable is fitted, that screen should be connected as indicated in the manual for the instrument the load link is connected to.
- ⦿ Cable length should not be added or removed from the load link, as this could alter the calibration figures.
- ⦿ Where junction boxes are used, check the connections are good quality and securely connected. Clean the enclosure and check that it is free from moisture.
- ⦿ Load link cabling must be kept away from high power cables and equipment, high output RF equipment and inductive loads and generators. **Cables must not be run alongside power cables.**

Load Link Output

The electrical output of the load link should be connected only to instrumentation with a high enough input impedance, preferably 1Mohm or greater, in order to prevent loading effects on the output sensitivity of the load link. LCM Systems offers a wide range of digital and analogue instruments ensuring compatibility.

When setting up your load link the following points should be acknowledged:

- ⦿ The zero load output given on the calibration certificate is the output of the load link when no load is applied. This includes the removal of the load caused by any lifting accessories.
- ⦿ The load on an installed load link will comprise of the weight of your assembly (including sheaves, blocks, shackles, ropes, hooks etc.) and the active load (load lifted). Therefore, the output with no active load will be greater than the zero output indicated on the calibration certificate.
- ⦿ The output from the load link can be in various forms, 4-20mA, 0-10V, mV/V etc. See the calibration certificate for details.

Checks After Installation

- ⦿ With the load link installed check the displayed output is not negative, as this may indicate either a fault or a compressive force is being applied to the load link. See section 1.5 and figure 2 for details on correct loading.
- ⦿ When applying load to the load link, the output should increase in the positive direction. Use the calibration certificate for reference as to the output observed at certain loads. If this is not the same then check the following:
 - a. All electrical connections are correct i.e. to an instrument or junction box.
 - b. If a connector is fitted, check that it is fully mated.

1.6 Calibration

All LCM Systems load links are calibrated in UKAS traceable test machines to best simulate normal loading conditions.

We endeavour to match the loading conditions that would be experienced in service but it is not possible to totally simulate the on-site structure for every load link manufactured. It is for this reason that for optimum system accuracy, a calibration in the final assembly is recommended. On-site calibration should be performed in accordance with the manual for the instrument the load link is connected to.

1.7 Warnings/Hazards

Load links are highly stressed devices and commonly have safety factors between three and five times the rated capacity under static conditions. Fatigue applications and environmental factors can contribute to reducing this margin. The user should determine media effects on the exposed load link materials. Where a corrosive environment is present load links can often be manufactured from corrosion resistant materials or alternatively, isolation barriers can be employed between the corrosive environment and the load link.

The following points should be followed to avoid potentially hazardous situations:

- ⦿ Do not weld near to installed load links, as leakage currents may destroy the load links electric circuits.
- ⦿ Load links are sealed units which must not be dismantled. Damaged load links should be returned to LCM Systems for repair and re-calibration.
- ⦿ The accuracy of the system is dependent upon correct installation of the load link.
- ⦿ Load links should not be handled or carried by means of the cable.
- ⦿ Load links must not be subjected to shock loads, such as using a hammer to force an assembly together (fitting clevis pins into the mounting holes).
- ⦿ The load link should never be placed in a potential explosive environment unless the product is suitably certified (ATEX or IECEx).

1.8 Inspection and Repair

Repair

Only LCM Systems personnel are authorised to carry out a repair to or service their products. All repairs or servicing will be carried out in the premises of LCM Systems. The unit is not serviceable outside of LCM Systems premises.

Inspection

All LCM Systems load links should be subject to periodic inspection, which should include, but is not exclusive to the following checks:

- ⦿ Completion of the checks after installation, see section 1.5 (Checks After Installation).
- ⦿ Check output at zero load (shift in zero offset). Verify against calibration certificate.
- ⦿ Inspect to see if the load link has been damaged/worn or chemically attacked (from a corrosive environment or lubricants etc.).
- ⦿ For cabled versions, verify the integrity of the cable.
- ⦿ After any serious operating incident, repeat first four checks above.
- ⦿ For load links fitted with a telemetry module, check that the batteries are correctly installed. The battery holder shows pictorially the correct orientation.
- ⦿ For load links fitted with a telemetry module, check for any signs of water ingress to the battery compartment and for any battery corrosion.
- ⦿ In the unlikely event of this device failing, fit new batteries (if applicable) and re-test. Only when this has been done should you report the fault. When reporting the fault, give a full description of the problem and the type of application the device is being used for.

DRAWINGS AND SPECIFICATION

Load measuring links are designed for many diverse lifting and weighing applications. The following range of LCM Systems load links can be supplied with various cable gland and connector configurations and signal conditioning boards.

2.1 Load Link Specification

LCM Systems load links are split into 3 different types, all of which have datasheets which can be found at the following website address: http://www.lcmsystems.com/load_monitoring_links.html

TLL	Standard design load links - LCM standard range
WLL	Standard design load links - LCM standard range
TOG	Standard design load links - LCM standard range

2.2 Cable Gland and Connector Configurations

All cable gland wiring colours or connector pin details are shown on the calibration certificate supplied.

The removal or replacement of the cable gland or bulkhead connector or any adjustment or repair must either be performed by LCM Systems or by a suitably qualified and approved engineer.

Examples of cable gland and connector arrangements:

Cable Gland Versions

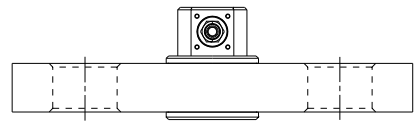
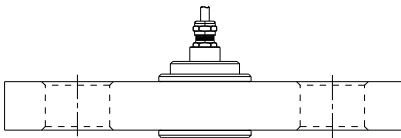
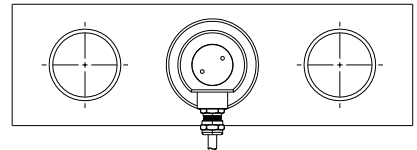
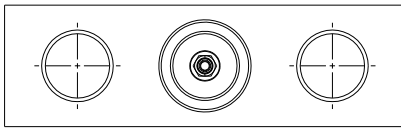

Cable With Hose Protection Versions

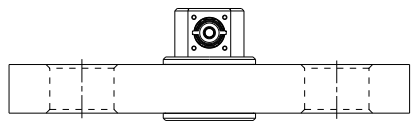
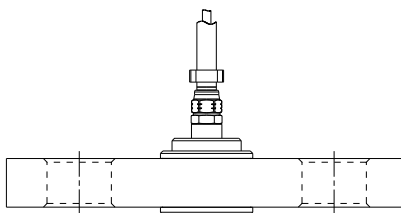
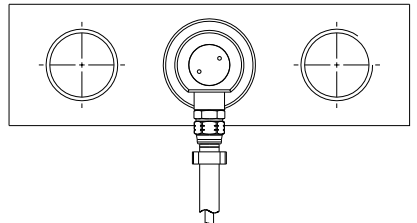
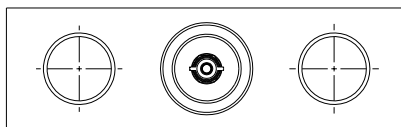

Connector Versions

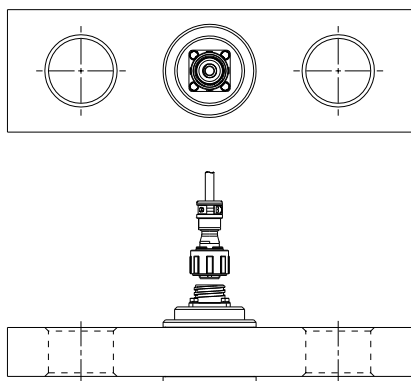

Standard TLL

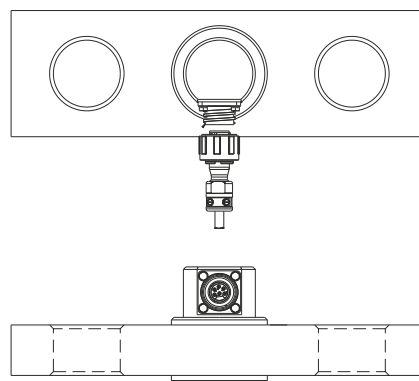

Standard TOG

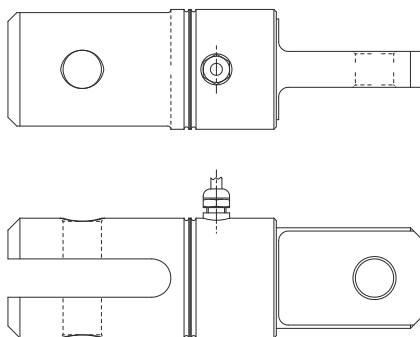

Mating and de-mating a connector assembly

- ⦿ Check both halves of the connector for any damage or obstructions.
- ⦿ Align the connector assembly and mate the two halves, press firmly to ensure they are fully engaged.
- ⦿ Tighten the locking sleeve, finger tight only to complete the mating process.
- ⦿ Always fully disengage the locking sleeve before attempting to de-mate the connector

2.3 Load Link Output Options

The load link can be fitted with a variety of built in (in-cell) signal conditioning boards, to offer either analogue, voltage, current signals or RS485 digital signals (in various protocols). When a wireless signal is required, the load pin can be fitted with a T24 Telemetry Module as shown in Figure 1.

ICA

The ICA analogue signal conditioning (amplifier) board is available in six versions, offering a range of current and voltage outputs. All amplifiers have a wide operating voltage range.

- ⦿ ICA1 - 3 wire, 0.1 to 10.1V
- ⦿ ICA2 - 3 wire, 0.1 to 5.1V
- ⦿ ICA3 - 4 wire, $\pm 10V$
- ⦿ ICA4 - 3 wire, 4 to 20mA
- ⦿ ICA5 - 2 wire, 4 to 20mA
- ⦿ ICA6, 3 wire , $\pm 10V$

See the ICA Datasheet and Instruction Manual for further details:

http://www.lcmsystems.com/ICA_In-Cell_Analogue_Strain_Gauge_Amplifier

DCELL

The DCELL Digital Signal Conditioning (amplifier) board offers high speed, RS485 and CANBus outputs in several protocols.

DCELL Communication:	RS485 Baud Rate	2400 Min to 230K Max
	Protocols	ASCII MANTRABUS II Modbus RTU MANTRACAN

See the DCELL Datasheet and Instruction Manual for further details:

http://www.lcmsystems.com/DCELL_In-Cell_Digital_Strain_Gauge_to_Data_Converter

Telemetry

The T24 product range uses high performance two-way radio communication. Each load link fitted with the telemetry module requires either a T24 handheld device, digital/analogue interface or a base station and PC to communicate with. See the T24 User Manual for further details on the T24 range of products:

<http://www.lcmsystems.com/T24>

**IF IN DOUBT ABOUT ANY ASPECT OF THE SELECTION,
INSTALLATION OR USE OF A LOAD LINK,
CONTACT LCM SYSTEMS FOR ADVICE BEFORE INSTALLING**

DECLARATION OF CONFORMITY



SAFETY COMPONENTS PUT ON THE MARKET SEPARATELY

LCM Systems Ltd. certifies that the load cells described hereafter are in accordance with the essential requirements defined in the European Machinery Directive 2006/42/EC and the related harmonised standards:

BS EN ISO 13849-1:2015 - Safety of machinery - Safety-related parts of control systems
Part 1: General principles for design

BS EN ISO 13849-2:2015 - Safety of machinery - Safety-related parts of control systems
Part 2: Validation

Technical files regarding the conformity of the products detailed herein are at the disposal of an authorised body on request.

This declaration is only valid for use with product types as detailed herein. Products must be used strictly according to the specifications and instructions detailed in this manual. The load cells are defined by their product datasheets, which are to be used in conjunction with this manual and their Calibration Certificate to ensure the correct maintenance and repair of the product.

Load Cell Type: Load Link - TLL, TOG, WLL, LCMXXXX (custom design)

Product Description: See corresponding product datasheets, calibration certificates and general arrangement drawings for full details.

To be in accordance with the CE requirements, the customer has to verify the compatibility between any electronics not supplied by LCM Systems (in accordance with referred directives in the industrial environment) and the LCM Systems load cells.

Company Details

LCM Systems Ltd
Unit 15, Newport Business Park
Barry Way, Newport
Isle of Wight
PO30 5GY
UK
Tel: +44(0)1983 249264
Fax: +44(0)1983 249266
E-mail: sales@lcmsystems.com

Quality Manager: Ray Leach

Date: 07/11/16

NOTICE

4.1 Copyright

The copyright and all rights of a like nature in respect of this document in any part of the world are the property of LCM Systems Ltd.

No part of this document may be reproduced or transmitted in any form or by any means, whether electronic, mechanical, photocopying, recording or otherwise, nor used for tendering or manufacturing, nor communicated to any other person without the written permission of LCM Systems Ltd.

The recipient of this document, as its registered holder, must exercise due diligence in ensuring that the above conditions are observed. (errors and omissions excepted). Any enquires relating to this document or its contents should be addressed, in writing, in the first instance to LCM Systems Ltd.

LCM Systems Ltd reserve the right to make changes to its products and specifications without notice.

4.2 About

LCM Systems is a specialist provider of standard and bespoke load cells, load pins, load shackles, load links and associated instrumentation, with over 30 years' experience in supplying innovative load measurement solutions to many different industries worldwide. Whatever the application and however demanding the environment, we can provide a system to meet your needs.

www.lcmsystems.com



LCM Systems Ltd

Unit 15, Newport Business Park
Barry Way, Newport
Isle of Wight PO30 5GY UK
Tel: +44 (0)1983 249264
Fax: +44 (0)1983 249266
sales@lcmsystems.com
www.lcmsystems.com